

WOS Series

WATER TREATMENT SYSTEMS

H2O

Equipment Services

Our mechanical oil/water separator systems are designed to remove free oils before discharging to your sanitary sewer. The oil/water/solids separators will reduce the amount of suspended solids while removing hydrocarbons to meet stringent local sanitary sewer discharge requirements.

Above-Ground Oil/Water/Solids Separator



WOS-30-0M10 with WX-0001 continuous recirculation option

The WOS Series offers the following features:

- Ozone is standard
- Stainless-steel tank
- Capability of handling oil and solids conveniently
- Takes up an extremely small footprint
- Easy to maintain
- CSA approved control panel which meets the requirements of the US and Canadian standards for Industrial Control Panel
- 1.0-HP surface-mount pump included

The WOS Series is perfect for the following applications:

- Rental Yards
- Heavy Equipment Dealers
- Trucking Facilities
- Military Bases
- Truck Rental Fleets
- Diesel Repair Facilities
- Forklift Washing Operations
- Aircraft Maintenance & Restoration
- Shipyards
- Municipalities/State DOTs
- Oil Fields
- Engine Rebuilders & Manufacturers

MODEL NUMBER	FLOW RATE	COALESCING MEDIA	TANK HOLDING CAPACITY	IN-LINE STRAINER PUMP	POWER REQUIREMENTS	DIMENSIONS (LxWxH)	SHIP WT.
WOS-15-0M10	0-15 GPM	672 sq. ft.	170 gallons	1.0 HP, 120V	120V, 10, 15.0A	91in.x31in.x40in.	675 lb.
WOS-15-0M30	0-15 GPM	672 sq. ft.	170 gallons	1.0 HP, 120V	208-230V, 30, 5.0A	91in.x31in.x40in.	675 lb.
WOS-30-0M10	0-30 GPM	1,152 sq. ft.	340 gallons	1.0 HP, 120V	120V, 10, 15.0A	97in.x50in.x44in.	865 lb.
WOS-30-0M30	0-30 GPM	1,152 sq. ft.	340 gallons	1.0 HP, 120V	208-230V, 30, 5.0A	97in.x50in.x44in.	865 lb.

ACCESSORIES:

PART NUMBER	DESCRIPTION	FITS MODELS
855-0002	Replacement media - Initial chamber	WOS-15 models
855-0010	Replacement media - Main chamber	WOS-15 models
855-0008	Replacement media - Main chamber	WOS-30 models
855-0009	Replacement media - Initial chamber	WOS-30 models

OPTIONS:

PART NUMBER	DESCRIPTION	FITS MODELS
WX-0001	Continuous recirculation - Recirculates back to the pit to prevent water from becoming stagnant	All models
WX-0057	230V, 1Ø	WOS-15-0M10
WX-0058	460V, 3Ø	WOS-15-0M30
WX-0059	230V, 1Ø	WOS-30-0M10
WX-0060	460V, 3Ø	WOS-30-0M30

WOS Series *Process & Flow Description*

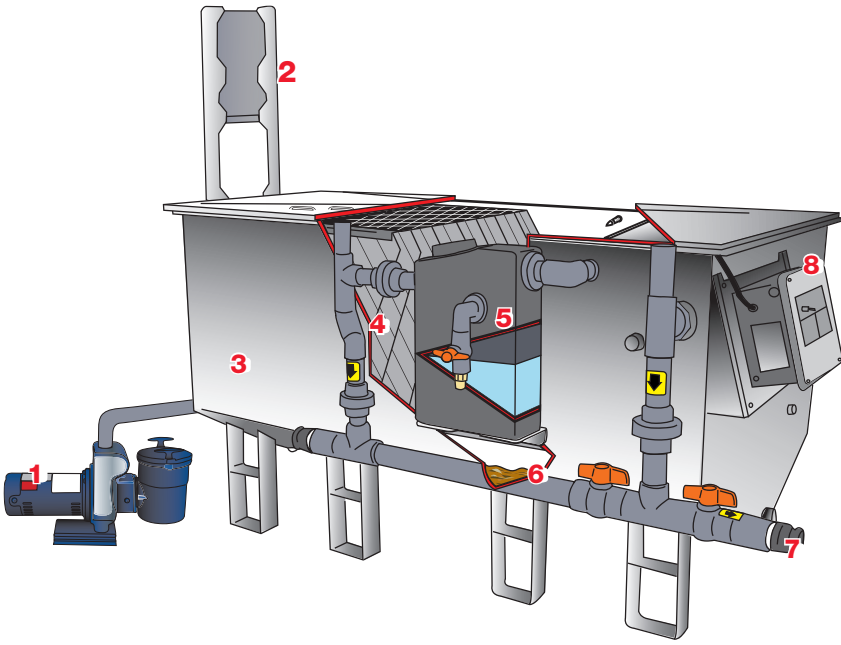

- 1. Surface-Mount Sump Pump** - Untreated wash-water is introduced into the system via a 1.0-HP surface-mount sump pump, which is included with the unit.
- 2. Corona Discharge Ozone System** - As the wash-water is pumped into the oil/water/solids separator, it is injected with a high concentration of ozone via a corona discharge ozone injector system for a "quick kill" of live bacteria on contact.
- 3. Three-Stage Stainless-Steel Tank** - As the water flows through the stainless-steel three-stage oil/water/solids separator, it changes the overall flow direction several times as it flows around four vertical baffles. The water is slowed down and fine silt and solids drop to the bottom of the tank.
- 4. Bio-Film Generative Media** - As the water progresses through hundreds of square-feet of honey-combed-shaped meshed oleophilic (oil attracting) coalescing media, it will change directions countless times. In this process, mechanically emulsified oil particles are attracted from the water to the oleophilic media, and float to the surface.
- 5. Oil Skimmer/Decanter** - Once the oil floats to the water's surface, it is then skimmed into an oil decanter for easy disposal.
- 6. Sloped Solids Trap** - Fine silt and particles are dropped to the bottom of the sloped stainless-steel tank for easy flushing and disposal of the accumulated solids.
- 7. Discharge Port** - Once the water has been treated, it flows into the final chamber of the stainless-steel tank and is gravity-fed through a 2-inch drain line to the sanitary sewer drain in the floor.
- 8. Electrical Control Box** - CSA listed NEMA-4 rated corrosion-proof control panel for safe and reliable operation.

Sample Equipment Wash Pad Application

Remote Box for Pressure Washer with Hose Reel & Wall Mount Bracket (#50-0196 & #13-0207A01)

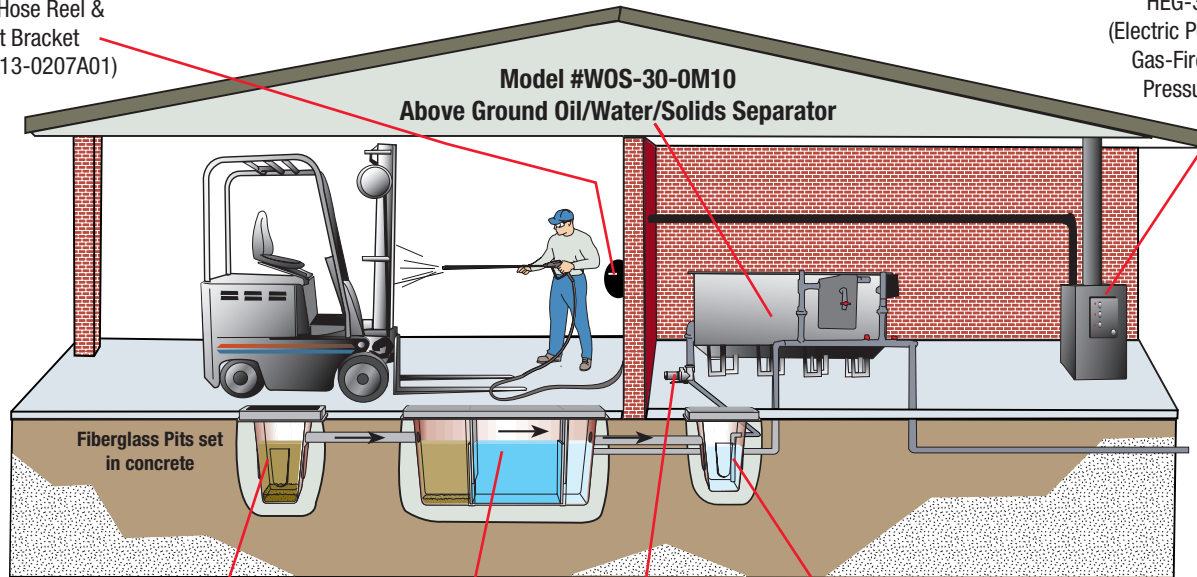

HEG-3004-0E2G
(Electric Powered Natural Gas-Fired Hot Water Pressure Washer)

Model #12-0071
3' x 3' Fiberglass Catch Basin

Model #12-0074
3' x 9' Fiberglass 3-Stage Collection Pit

Model #3-0328
1.0 HP Surface-Mount Sump Pump Included with System

Model #12-0073
2' x 2' Fiberglass Sump Pit

Information on Fiberglass Pits available in the Pit System Brochure.

The Importance of a Proper Pit System

Once equipment is washed, the untreated wash-water flows into your pit system. A proper pit system for your application is the first step in proper wash-water treatment, and a critical element in any wash-water recycle system.

We can help you determine the pit system configuration that works best with your application.

